

Masport®

EUROPEAN REEL LAWN MOWERS

MASPORT 500

<u>Part Number</u>	<u>Model</u>	<u>Engine</u>
019085	R/MWR 500 PRR EU GRN	B&S 3.5

Month and Year of First Manufacture - November 2010
SERIAL NUMBER FROM - 7353586



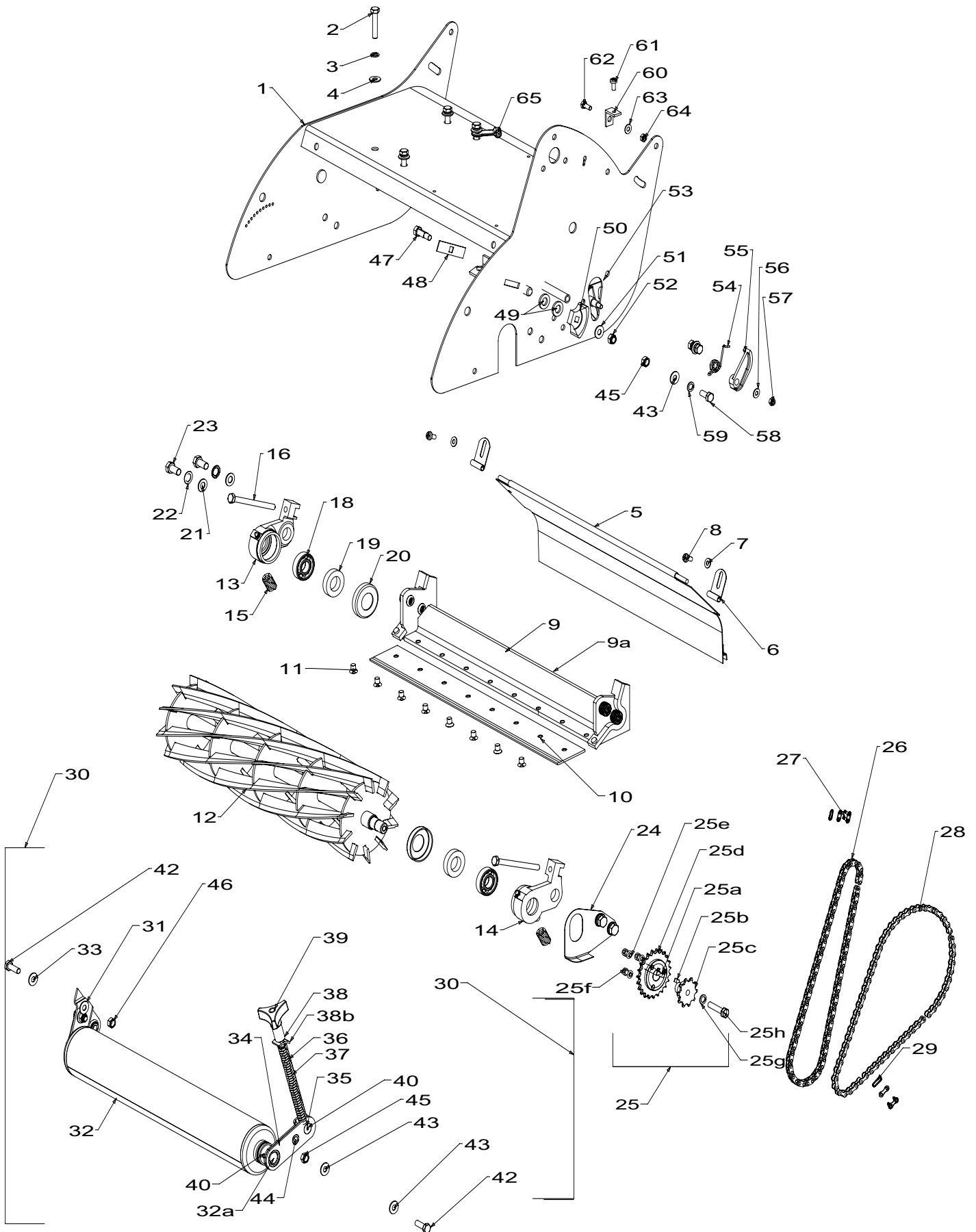

When ordering PLEASE QUOTE PART NUMBER & Description, NOT Illustration No.
Determine right or left hand side from standing in operating position (standing at handle)



Item No	Part No	Description	Qty	Item No	Part No	Description	Qty
1	031590	Chassis Assy- 500 Green	1	28	032044	Chain 0.23xP 3/8,76	1
2	501843	Screw, Set M8x40 Hex	4	29	731971	Link, Chain 1/2	1
3	503747	Washer, Spg 8	4				
4	501606	Washer, Flt 8x19x1.6	4				
5	008901	Deflector, Grass- 500	1	30	032026	Spindle & Brkt Assy 500	1
6	002589	Bracket, Grass Chute	2	31	*004983	Bracket- Front Roller, RH	1
7	501703	Washer, Flt 6x14x1.2	2	32	*032039	Front Roller Assy 500	5
8	503591	Screw, Pan M6x12	2	32a	*004977	Spindle Assy Front 500	1
9	032035	BracketPlate, Blade Assy 500 (incl items 10,11)	1	33	*501432	Washer, Flt 20x33x4.0	2
9a	009862	Bracket Assy Backplate	1	34	*004984	Bracket Assy- Adj, Front Roller	1
10	032021	Blade, Baseplate 500	1	35	*004990	Spindle, Trunnion	1
11	008611	Screw, CSK M8x12 Allen 500	8	36	*004988	Spindle- Adj, Front Roller	1
12	032018	Cylinder & Assy Cut Key 500	1	37	*004691	Spring- Height Adjust	1
	*032006	Blade Reel 500	1	38	*031910	Spacer- Knob	1
	*032008	Spindle Reel Key	1	38a	*004973	Plate Slipper	1
	*032016	Spindle Reel 10 Slot	1	39	*574230	Knob- Plastic, M8 Insert	1
13	032023	Housing- Assy Bearing, RH	1	40	*503369	Pin, Tension 6.0x30	2
14	032024	Housing- Assy Bearing, LH	1	42	*501598	Screw, Set M8x25 Hex	2
15	002581	Spring- Baseplate	2	43	*501606	Washer, Flt 8x19x1.6	6
16	006282	Screw, Set NF 5/16"x4" Hex	2	44	*004991	Bush- Pivot, Front Roller	2
17	007240	Nut, NF 5/16 Hex Nyloc Type "P"	2	45	*501602	Nut, M8 Hex	3
18	503273	Bearing, Ball 17x40x12 6203 2S	2	46	*501597	Screw, Set M8x20 Hex	1
19	002583	Seal- Felt	2				
20	005211	Cover- Dust, Cylinder Bearing	2	47	002848	Bolt- Adjuster, Chain	1
21	501704	Washer, Flt 10x19x1.6	4	48	002845	Sealplate- Chain Adjuster	1
22	503897	Washer, Spg 10	4	49	006028	Washer, Flt 12x22x3.0	4
23	501760	Screw, Set M10x20 Hex	4	50	002844	Adjuster- Chain, Fixed Nylon	1
24	002561	Plate- Seal, Chaincase	1	51	501606	Washer, Flt 8x19x1.6	1
25	032006	Sprocket Assy10/23 Key (incl items 25a-25h)	1	52	501793	Nut, M8 Hex Nyloc 8 Thck	1
25a	*032005	Key 5x5x16	1	53	004942	Plate Assy, Mounting	1
25b	*032004	Key 5x5x10	1	54	004945	Spring	1
25d	*032045	Sprocket Assy - 23 Key (incl items 25c,25e and 25f)	1	55	004963	Adjuster- Chain, Tension Nylon	1
25c	*032003	Sproket 23T	1	56	501703	Washer, Flt 6x14x1.2	1
25e	*502004	Screw,Cap M6x12	3	57	501764	Nut, M6 Hex Nyloc 6 Thck	1
25f	*500201	Washer,Spg	3	58	501597	Screw, Set M8x20 Hex	1
25g	*501843	Screw Set M8 x 40	1	59	501703	Washer, Flt 6x14x1.2	1
25h	*503747	Washer Spg 8	1	60	031915	Bracket- Chain Cover	1
26	042099	Chain, 0.23xP 3/8, 75P	1	61	503591	Screw, Pan M6x12	1
27	731972	Link, Chain 3/8	1	62	501702	Screw, Set M6x15 Hex	1
				63	501703	Washer, Flt 6x14x1.2	1
				64	501764	Nut, M6 Hex Nyloc 6 Thck	1
				65	581527	Retainer, Clutch Cable	1

Bold Text = Assemblies
Bulleted Text = Items included in Assemblies

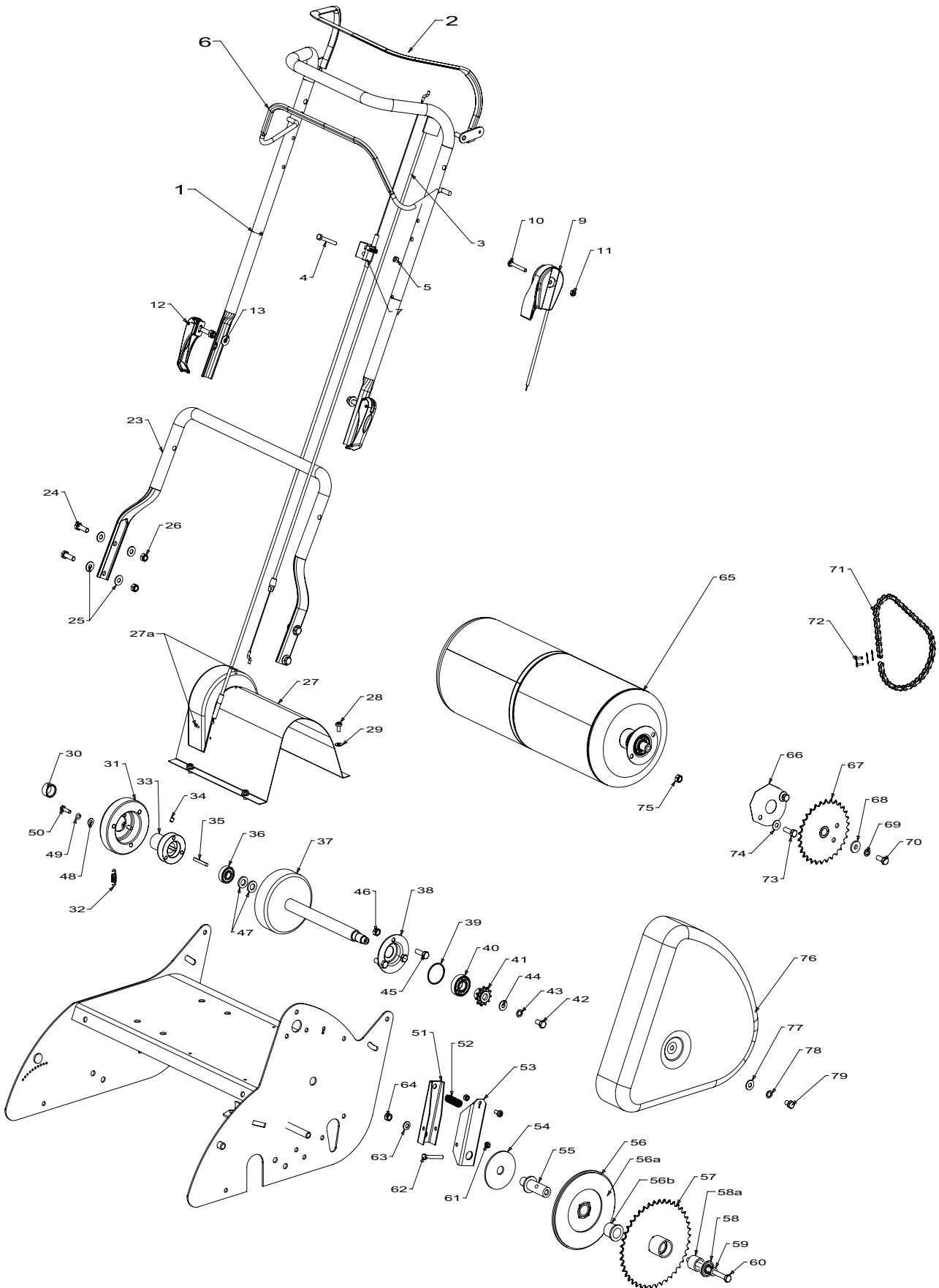

When ordering PLEASE QUOTE PART NUMBER & Description, NOT Illustration No.
Determine right or left hand side from standing in operating position (standing at handle)



Item No	Part No	Description	Qty	Item No	Part No	Description	Qty
1	973155	Handle- Upper, Upt ADJ	1	50	503223	Screw, Set M6x16 HT8.8 Hex	
2	579279	Bail Arm Assy, SP MSV	1			__==__	
3	031990	Cable- Clutch, Thumb Wheel	1	51	031831	Lever- Clutch	1
4	503558	Screw, Set M6x45	1	52	031845	Spring- Clutch	1
5	501764	Nut, M6 Nylocx 6 Thck	1	53	031830	Lever Carrier- Clutch	1
6	579278	Bail Arm Assy, OPC	1	54	031843	Washer. Flt 16.5x75x3.0	1
7	031878	Cable- Engine, OPC	1	55	031840	Post- Clutch	1
8	501365	Clip- Starlock, 5/16"	2	56	031986	Sprocket- Clutch Plate Assy	1
9	583458	Control- Throttle,Hsng Wscn	1	56a	031987	Liner- Clutch Face Cork	1
10	503604	Screw, Pan M6x45	1	56b	031853	Bush BackPlate	1
11	501764	Nut, M6 Nylocx 6 Thck	1	57	031963	Sprocket- 42T, Plate & Boss Assy	1
12	779755	Cam Lock Assy	2	58	503901	Bearing, Ball 12x28x8 6001 2RSH	1
13	501606	Washer, Flat 8x19x1.6	2	58a	031834	Bush Sprocket	1
		__==__		59	031965	Washer- Centralizing Brass	1
23	031849	Handle- Lower, 500	1	60	503938	Bolt, M8x120 Hex	1
24	501598	Screw, Set M8x25	4	61	501764	Nut, M6 Nyloc 6 Thck	1
25	501606	Washer, Flat 8x19x1.6	4	62	580160	Screw, Set M6x50 Hex	1
26	501793	Nut, M8 Nylocx 8 Thck	4	63	031842	Washer, Thrust	1
		__==__		64	501793	Nut, M8 Hex Nyloc 8 Thck	1
27	031909	Cover- Trans, 500/660 GRN	1			__==__	
27a	503429	Rivet Pop 3.2 x4.8 73 AS4-3	4	65	031918	Rear Roller Assy, Complete 500	1
28	503591	Screw, Pan M6x12	4	66	002618	Plate- Seal, Bearing	1
29	501703	Washer, Flt 6x14x1.2	4	67	002604	Sprocket & Boss Assy, Rear Roller	1
30	031958	Spacer- Drive Shaft, 13mm	1	68	503872	Washer, Flt 8x20x3.0	1
31	031912	Clutch- Drive Assy	1	69	503747	Washer, Spg 8	1
32	031845	Spring Clutch	1	70	501717	Screw, Set M8x20 1mm Pitch	1
33	031913	Boss- Clutch, 19 Dia B&S	1	71	004929	Chain, 3/16" x 1/2, 40P	1
34	501719	Screw, Grb M6x8	2	72	731971	Link, Chain 1/2	1
35	536012	Key- Engine 3/16"SQ x 38	1	73	501598	Screw, Set M8x25	2
36	501213	Bearing, Ball 12x32x10 6201 2RS	1	74	501606	Washer, Flt 8x19x1.6	2
37	031587	Drum Assy, Clutch 500/660	1	75	501602	Nut M8 Hex	2
38	002834	Housing- Bearing	1	76	031909	Cover - Chaincase- Green	1
40	503273	Bearing, Ball 17x40x12 6203 2S	1	77	501606	Washer, Flt 8x19x1.6	1
41	002818	Sprocket- 11T, Drive	1	78	503747	Washer Spg 8	1
42	501715	Screw, Set M8x15 1mm Pitch	1	79	501863	Screw Set, M8x12	1
43	503747	Washer, Spg 8	1			NOT ILLUSTRATED	
44	501606	Washer, Flt 8x18x1.6	1		031880	Safety Switch Housing	1
45	501598	Screw, Set M8x25 Hex	3		031881	Safety Switch Cover	1
46	501602	Nut, M8 Hex	3		031885	Safety Switch Lever Arm	1
47	006028	Washer, Flt 12x22x3.0	2		031882	Safety Switch Loom	1
48	501703	Washer, Flt 6x14x1.2	3		032078	Owners Manual	1
49	500201	Washer, Spg 6	3		031886	Spring	1

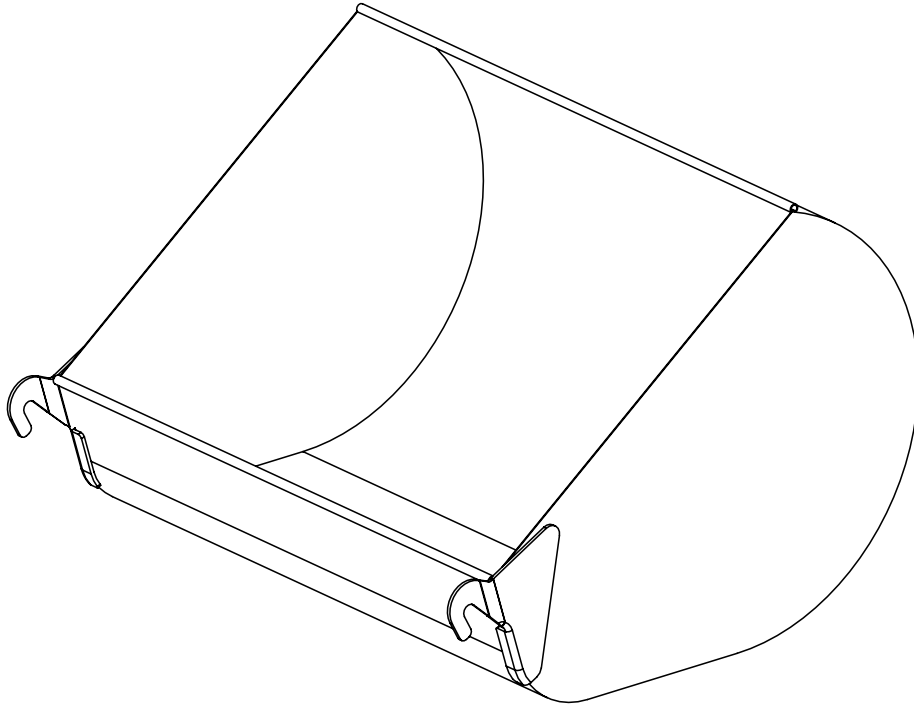

731969 Catcher Assy, 500 Plastic Green 1